

ICC-ES Evaluation Report

ESR-2601*

Reissued May 1, 2011

This report is subject to renewal May 1, 2012.www.icc-es.org | (800) 423-6587 | (562) 699-0543

A Subsidiary of the International Code Council®

**DIVISION: 06 00 00—WOOD, PLASTICS, AND
COMPOSITES****Section: 06 50 00—Structural Plastics****Section: 06 63 00—Plastic Railings****REPORT HOLDER:**

FYPON, LTD.
8055 NORTH STATE ROAD 9
HOWE, INDIANA 46746
260-868-5811
www.fypon.com
sjasperson@thermatru.com

EVALUATION SUBJECT:**QUICKRAIL™ SYNTHETIC RAILING SYSTEM****1.0 EVALUATION SCOPE****Compliance with the following codes:**

- 2009 and 2006 *International Building Code*® (IBC)
- 2009 and 2006 *International Residential Code*® (IRC)

Properties evaluated:

- Structural
- Durability
- Surface-burning characteristics

2.0 USES

The Quickrail™ Synthetic Railing System described in this report is limited to exterior use as guards for balconies, porches, decks and stairs. The products described in this report are used in exterior applications in Group R Occupancies (residential) in buildings of Type V-B (IBC) construction and other types of construction in applications where untreated wood is permitted by IBC Section 1406.3 or in buildings constructed in accordance with the IRC.

3.0 DESCRIPTION**3.1 General:**

The Quickrail™ Synthetic Railing System is a guard consisting of post sleeves and caps and top and bottom rails, with aluminum and synthetic inserts, balusters, bottom-rail support block and an optional guardrail post (Ultra-Post). The Quickrail™ Synthetic Railing System components are 100 percent PVC except for the aluminum and synthetic insert, which is made from aluminum alloy

6063-T6 and mica- and glass-reinforced polypropylene, and the Ultra-Post guardrail post which is made of steel tubes and plates. The minimum yield and tensile strengths, and minimum thickness of the aluminum inserts and steel tubes and plates are specified in the approved quality control manual. The Quickrail™ Synthetic Railing System is available in white and desert sand colors.

3.2 Guard:

The height of the railing assembly is 36 inches or 42 inches (914 or 1067 mm) above the walking surface. Each post is covered with a 4-inch-by-4-inch PVC sleeve. The top rail has a T-shape and the bottom rail is rectangular. The T-shaped rail is 3¹/₄ inches (82 mm) wide at the top and 2¹/₄ inches (57 mm) wide at the bottom, and has a total depth of 3³/₄ inches (95 mm) and a wall thickness of 0.125 inch (3.2 mm). The rectangular bottom rail is 2 inches (50.8 mm) wide at top and bottom, and has a depth of 3¹/₂ inches (89 mm) and a wall thickness of 0.14 inch (3.6 mm). Both top and bottom rails are available in 6-foot, 8-foot and 10-foot (1.83, 2.44 and 3.05 m) lengths.

The balusters are hollow, thermal formed spindles and square, co-extruded hollow pickets. The spindles are 1¹/₂ inches (38.1 mm) square at the top and bottom. The pickets are 1¹/₂ inches (38.1 mm) square. When the pickets or spindles are installed into the rails, there is a clear space of approximately 3¹/₄ inches (82.5 mm) between pickets or spindles.

The post sleeves are 4 inches (102 mm) square and have a wall thickness of 0.186 inch (4.7 mm). See Figure 1 for dimensioned profiles of the post sleeves, top and bottom rails, top rail aluminum inserts and synthetic inserts, and balusters. The top rail mounting brackets are made from molded plastic or galvanized steel and the bottom rail mounting bracket is made from molded plastic. The 10-foot (3.05 m) rail systems utilize two intermediate bottom rail supports (located at one-third points), while the 8-foot and 6-foot (2.44 m and 1.83 m) rail systems utilize one intermediate bottom rail support located at the midspan.

The Ultra-Post guardrail post is a Q195 steel tube measuring 0.109 inch [12 gauge (2.8 mm)] thick, welded to a 3¹/₂-inch (89 mm) square and 3³/₈-inch-thick (9.5 mm) galvanized Q235 steel leveling plate. Two PVC guide blocks are positioned onto the post mount so that the screws from the railing brackets will screw into the guide blocks. Ultra-Post is available in heights of 36 and 42 inches (914 mm and 1067 mm). See Figure 3 for a profile of the UltraPost.

***Revised February 2012**

3.3 Durability:

When subjected to weathering, insect attack, and other decaying elements, the material used to manufacture the Quickrail™ Synthetic Railing System is equivalent in durability to code-complying, preservative-treated or naturally durable lumber when used in locations described in Section 2.0 of this report. The Quickrail™ Synthetic Railing System has been evaluated for structural performance when exposed to temperatures from -20° (-29°C) to 125°F (52°C).

3.4 Surface-burning Characteristics:

When tested in accordance with ASTM E84, the Quickrail™ Synthetic Railing System PVC has a flame-spread index of no greater than 200.

4.0 DESIGN AND INSTALLATION

4.1 General:

Installation of the Quickrail™ Synthetic Railing System must comply with this report and the manufacturer's published installation instructions. The manufacturer's published installation instructions must be available at the jobsite at all times during installation.

4.2 Design:

The Quickrail™ Synthetic Railing System is satisfactory to resist the loads specified in Section 1607.7.1 of the IBC and Table R301.5 of the IRC, when installed at a maximum 10-foot (3.05 m), inside-to-inside post spacing. When the railing is supported on one or both ends by the supporting construction, the maximum distance must be measured from edge-of-post to edge-of-structure or from edge-of-structure to edge-of-structure. See Table 1 for actual measurement of rail and maximum spans. When using the Ultra-Post guardrail post, the Quickrail™ Synthetic Railing system is able to resist a maximum guard span of 8 feet as indicated in Table 2.

4.3 Installation:

4.3.1 Quickrail™ Synthetic Railing System Post Sleeves: The Quickrail™ Synthetic Railing System must be fastened to the Ultra-Post guardrail post, or to other posts or a structure that complies with the applicable code.

4.3.2 Quickrail™ Synthetic Railing System: The Quickrail™ Synthetic Railing System is a 6-, 8- and 10-foot-long (1.83, 2.44 and 3.05 m) assembly in which the top rail is a hollow T-section and the bottom rail is a hollow, 2-inch-by-3¹/₂-inch (51 by 89 mm), rectangular member. The assembly has aluminum or synthetic inserts in the top rail only or no insert at all. The top rails are attached to a post and sleeve, rigid column or building wall with a galvanized steel bracket or a nylon bracket. The top rails being attached with the steel brackets are secured with six No. 10 by 2¹/₂-inch-long, (64 mm), stainless steel flat-head wood screws on a level rail and four No. 10 by 2¹/₂-inch-long, (64 mm), stainless steel flat-head wood screws for a stair rail. The top bracket is secured to the top rail with two No. 8 by 3/4-inch-long (19 mm) screws on any rail over 6 feet (1.83 m) long, or four No. 8 by 3/4-inch-long, (19 mm) screws on rails 6 feet (1.83 m) long. The top rails attached to the supporting construction by the nylon brackets are attached using four No. 10 by 1¹/₂-inch-long Phillips pan-head, self-drilling, plated steel screws. Six-foot-long (1.83 m) top rails do not have an insert. Top rails over 6 feet (1.83 m) long, and up to 8 feet (2.44 m) long, have a synthetic insert. Top rails over 8 feet (2.44 m) long, and up to 10 feet (3.05 m) long, have an aluminum insert. All bottom rails are attached to a post and sleeve, rigid column or building wall with a plastic socket bracket secured with

four No. 10 by 2¹/₂-inch-long (64 mm), stainless steel, pan head wood screws. The bottom rail and socket bracket are installed as a slip-on fit without screws between the rail and the bracket. The balusters are either 1¹/₂-inch (38 mm) square pickets or 1¹/₂-inch (38 mm) molded spindles, and are spaced 3¹/₄ inches (83 mm) apart (open clear space). The top and bottom rails are routed to accept the spindles and pickets with no further attachment.

5.0 CONDITIONS OF USE

The Quickrail™ Synthetic Railing System described in this report complies with, or is a suitable alternative to what is specified in, those codes listed in Section 1.0 of this report, subject to the following conditions:

- 5.1 These products are limited to exterior use as a guardrail system for balconies, porches, decks and stairs used in exterior applications in Group R Occupancies (residential) in buildings of Type V-B (IBC) construction and other types of construction in applications where untreated wood is permitted by IBC Section 1406.3 or in buildings constructed in accordance with the IRC.
- 5.2 Installation must comply with this report, the manufacturer's published installation instructions and the applicable code. When the manufacturer's published installation instructions differ from this report, this report governs.
- 5.3 The compatibility of the fasteners and brackets with the supporting construction, including chemically treated wood, is outside the scope of this report.
- 5.4 The Quickrail™ Synthetic Railing System must be directly fastened to supporting construction having adequate strength and stiffness. Where required by the code official, engineering calculations and construction documents consistent with this report must be submitted for approval. The calculations must verify that the supporting construction complies with the applicable building code requirements and is adequate to resist the loads imparted upon it from the products and systems discussed in this report. The documents must contain details of the attachment to the supporting structure consistent with the requirements of this report. The documents must be prepared by a registered design professional where required by the statutes of the jurisdiction in which the project is to be constructed.
- 5.5 The top rail component of the Quickrail™ Synthetic Railing System must not be used as a handrail for stairways or ramps.
- 5.6 The use of wood posts, with or without post sleeves, is outside the scope of this report.
- 5.7 The Quickrail™ Synthetic Railing System is produced in Howe, Indiana, under a quality control program with inspections by Architectural Testing, Inc. (AA-676).

6.0 EVIDENCE SUBMITTED

Data in accordance with the ICC-ES Acceptance Criteria for Deck Board Span Ratings and Guardrail Systems (Guards and Handrails) (AC174), dated July 2010.

7.0 IDENTIFICATION

The Quickrail™ Synthetic Railing System described in this report is identified by a stamp, on each individual piece or on the packaging, bearing the manufacturer's name (Fypon), the product name, the allowable span, the name of the inspection agency (Architectural Testing, Inc.), and the ICC-ES evaluation report number (ESR-2601).

TABLE 1—MAXIMUM GUARDRAIL SYSTEM SPANS¹

PRODUCT NAME/COMPONENT ⁵	APPLICABLE BUILDING CODE ²		MAXIMUM SPAN ^{3,4} (ft.-in.)
	IBC	IRC	
QuickRail™ 42 inches high with aluminum insert	Yes	Yes	10 - 0
QuickRail™ 42 inches high with synthetic insert	Yes ⁷	Yes	8 - 0
QuickRail™ 42 inches high with no insert	Yes	Yes	6 - 0
QuickRail™ 36 inches high with aluminum insert	--	Yes	10 - 0
QuickRail™ 36 inches high with synthetic insert	--	Yes	8 - 0
QuickRail™ 36 inches high with no insert	--	Yes	6 - 0

For SI: 1 inch = 25.4 mm, 1 foot = 305 mm.

- ¹The ability of the supporting construction to resist the reactionary loads must be justified to the satisfaction of the code official.
- ²Indicates compliance with the respective building codes.
- ³Maximum span is measured from edge-of-post to edge-of-post.
- ⁴Maximum allowable span has been adjusted for durability. No further increases are permitted.
- ⁵The minimum height of the top rail is 42 inches for the IBC (Section 1013.2) and 36 inches for the IRC (Section R312).
- ⁷Limited to use as level guards in the IBC; and level guards and guards for stairs in buildings constructed to the IRC.

TABLE 2—MAXIMUM GUARDRAIL SYSTEM SPANS SUPPORTED BY ULTRA-POST¹

HEIGHT OF ULTRA-POST (inches)	MAXIMUM SPAN SUPPORTED (feet)
36	8
42	8

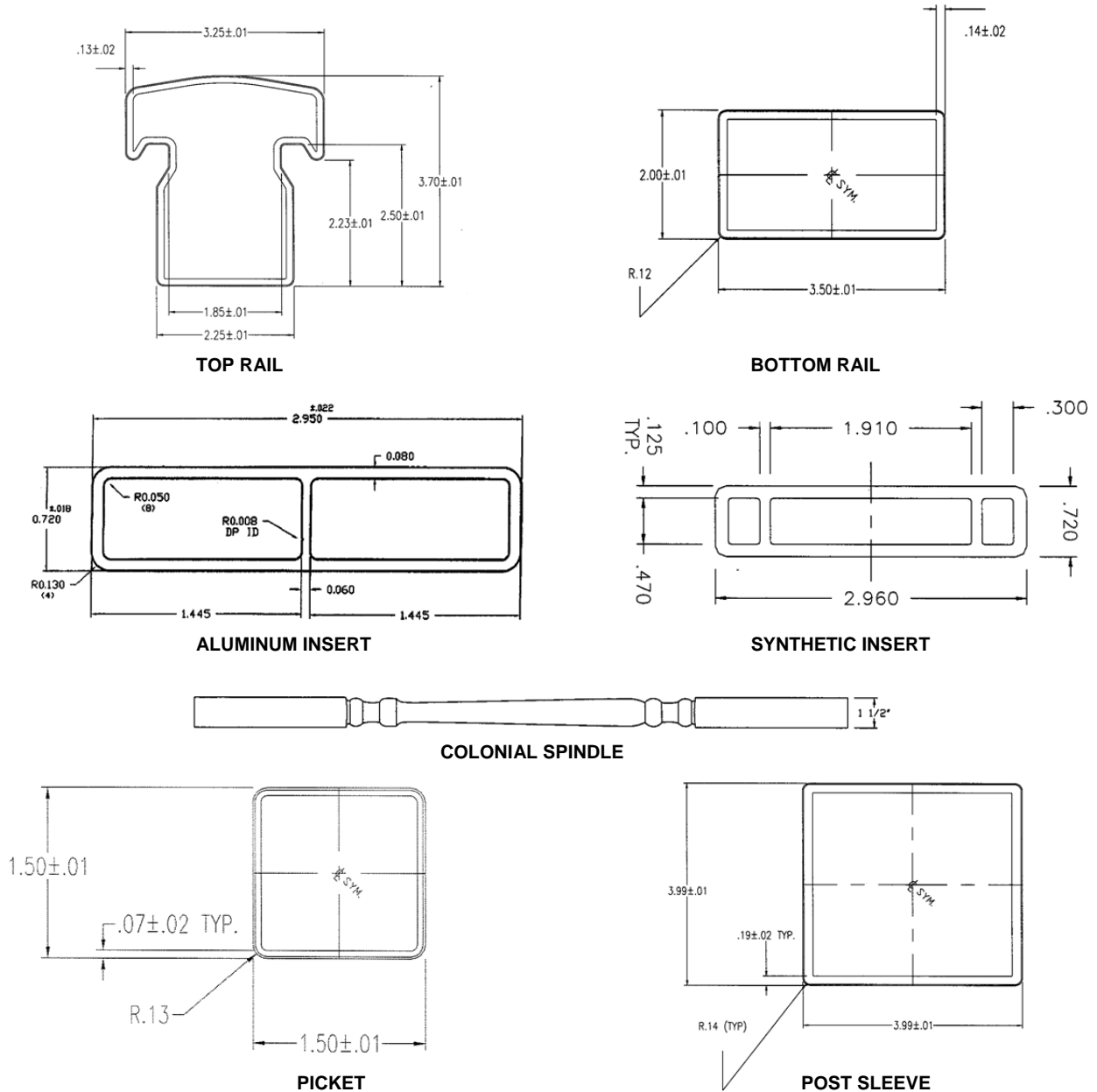
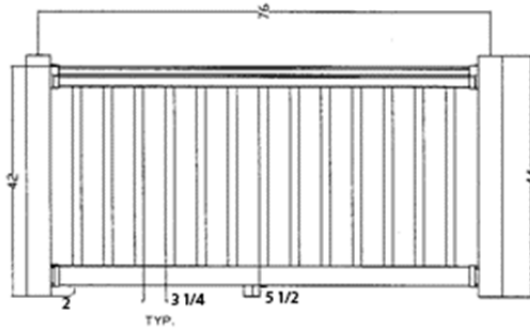
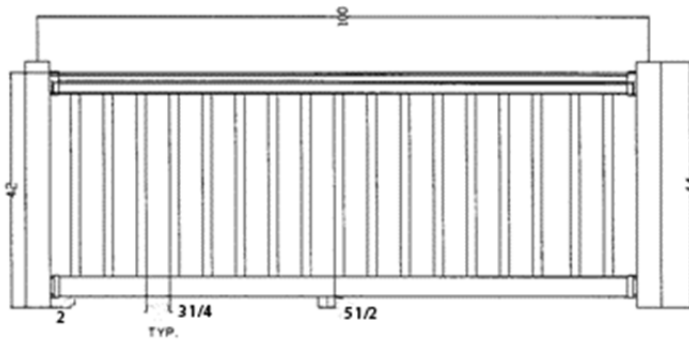

FIGURE 1—CROSS SECTIONS

72" by 42" QuickRail™



96" by 42" QuickRail™



120" by 42" QuickRail™

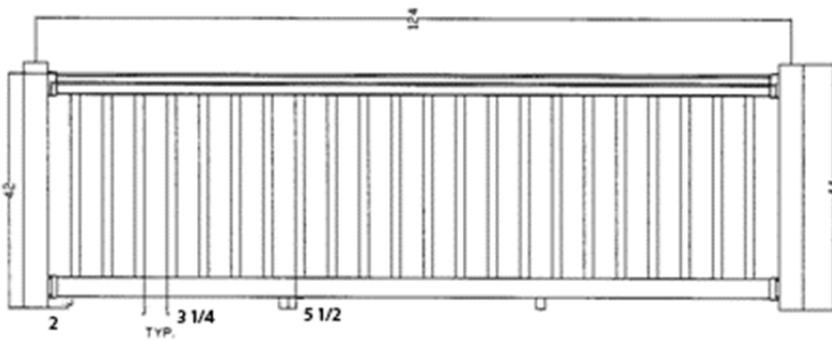

FIGURE 2—ASSEMBLIES

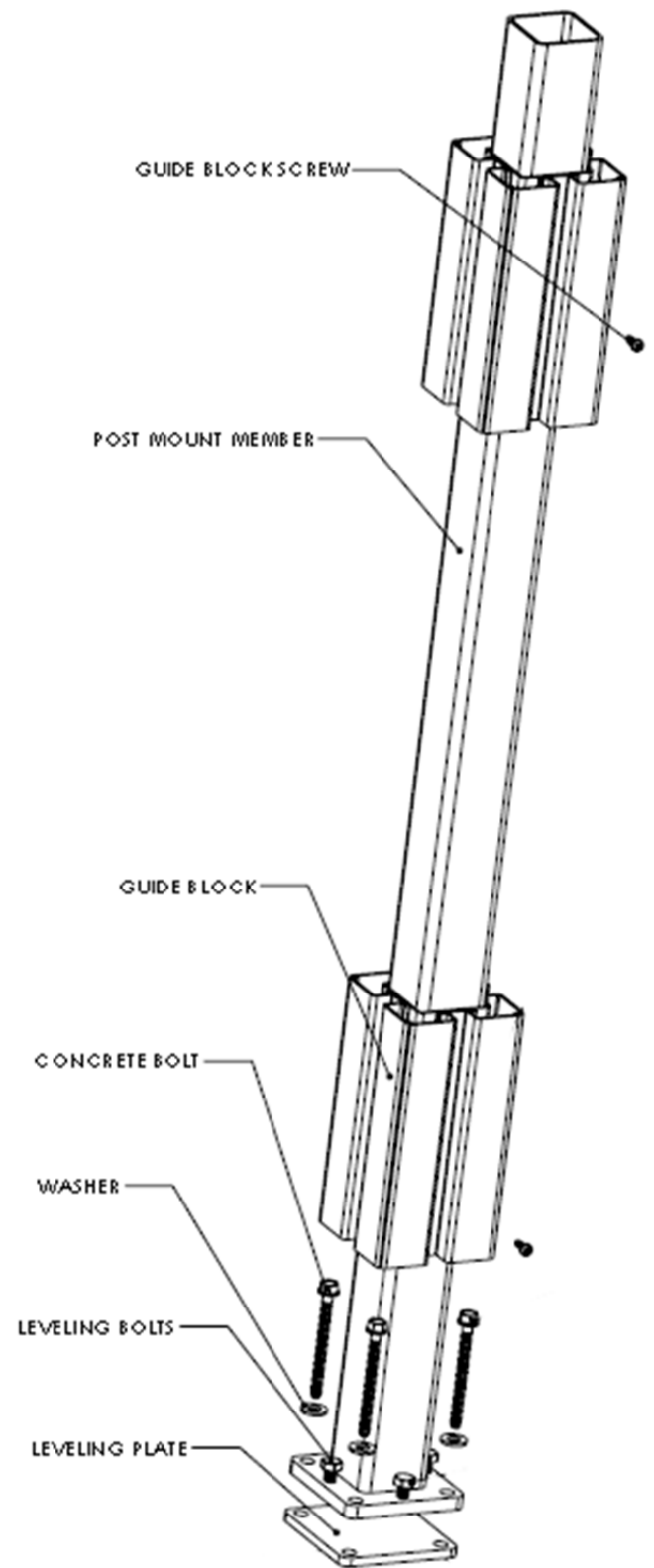

FIGURE 3—ULTRA POST